

REGALBOARD

TECHNICAL DATA SHEET

Version: B1.0 | 2025-06-03



Before installing, please ensure you have downloaded the latest version of this TDS by scanning this code.

www.eva-last.com

A PRODUCT BY **EVA-LAST**[®]
INSPIRED BY NATURE, DESIGNED FOR LIFE.

Contents

Document guide	3
Material composition	4
Physical properties	4
Profile properties	5
Mechanical properties	6
Thermal properties	8
Fire reaction properties	9
Weathering	10
Slip resistance	11
Disclaimer and copyright	12
Appendix A: Profile Drawings	13
Appendix B: Chemical Compactability	21

RegalBoard Mineral-Polymer composite decking

RegalBoard is an innovative building material moulded from natural wood, offering the aesthetic appeal of wood with the benefits of ultra-low maintenance. Unlike natural wood, RegalBoard requires no costly staining, sealing, or varnishing. This makes it an ideal choice for exterior applications where durability and ease of care are essential.

Product name:	RegalBoard decking
Product use:	Primarily used in decking, fascia, and similar applications
Material:	RegalBoard
Material description:	Co-extruded profiles with a foamed PVC Core

Document guide

Eva-Last strives to evaluate their products in depth and present the technical and safety information available in a manner that assists with the application thereof. If additional data or information is required, please do not hesitate to contact us at rad@eva-last.com.

In an attempt to simplify the information, similar data is loosely grouped into the categories summarised below. This document is ordered according to these categories and the applicable page number for the start of each section captured in the Table of contents above.

- Material composition
- Physical properties
- Mechanical properties
- Thermal properties
- Fire reaction properties
- Weathering properties
- Surface properties

The Material compositions section captures a summary of the product make-up from the Material Safety Data Sheet (MSDS). A link to the MSDS is provided for additional detail. Summaries of chemical compliance data available are also collected in this section.

The Physical properties section provides a summary of available profiles and general material properties such as density, water absorption, etc. Additional profile information can be obtained from drawings in the appropriate appendix. Where possible, material properties that can be assigned to more specific categories are moved to the relevant section.

The Mechanical properties section captures data related to the product's reaction to various load conditions. The section is broadly assembled into the below categories. Additional profile and sectional information are captured by the drawings in the appropriate appendix.

- Material specific mechanical properties
- Profile specific mechanical properties
- Sectional properties

Product properties such as the expansion coefficient, thermal resistance, etc. are captured, where applicable, in the Thermal properties section.

Information regarding the product's reaction to fire is captured in the Fire reaction properties section.

Test data relating to the acoustic performance of the, where applicable, is summarised in the Acoustic properties section.

Information on the product's resistance to mold, termites, etc. is collected in the Biodegradation properties section.

The Surface properties section summarise information regarding the finish or texture of the product. Test data on aspects such as slip resistance (where applicable) is captured in section.

Where the products form part of a system and, as a result, utilise other components, an additional section to capture useful data regarding these components is added to the document.

Where information is not yet available, the section is simply omitted. In the cases where information can be substituted or supplemented with alternative data (based on similar compositions, etc.), an attempt to do so is made. Where this is the case, it is highlighted. Please make use of the data accordingly. For any additional information regarding this, please feel free to contact rad@eva-last.com.

Ensure the product and application thereof is suitable, rational, and compliant with any applicable regulations or standards. Wherever necessary, consult a suitably qualified professional. For information about the installation and use of the product, please see the applicable Installation Guide (IG). For additional material safety and handling information, please refer to the applicable MSDS. For any further information, please contact rad@eva-last.com

Material composition

The following table is a simplified material composition for the RegalBoard material technology. For more information regarding the composition, safety, and handling of the material, please contact rad@eva-last.com. To confirm which substances are compatible, or incompatible, with the product, please refer to Appendix B.

Component	Substance	Mass (%)
Cap	Polyurethane (PU)	3%
Core	Polyvinyl chloride (PVC)	48%
	Calcium carbonate	28%
Additional additives	Other	21%

Physical properties

General material properties

Typical properties of the RegalBoard material technology are captured below as an indication of the expected behaviour.

See **Report No. 220929020SHF-001-R1**

Properties	Results	Test method	Notes
Density	0.868 g/cm ³ (0.0314 lb/in ³)	ISO 1183-1:2019	Page 4 of listed report.
Maximum Water Absorption	2.40%	EN 15534-1:2014	The boards were immersed in water for 28 days at ambient temperatures of 23 °C. See Page 12 of listed report.
Maximum Swelling	Thickness 0.33%	EN 15534-1:2014	
	Width 0.09%	EN 15534-1:2014	
	Length 0.10%	EN 15534-1:2014	
Boiling Test (Water Absorption)	21.2% (mean)	EN 15534-1:2014	The test procedure involves immersing specimens in boiling water for 5 hours, followed by immediate immersion in cold water for 15 minutes, and then testing them at controlled temperature and humidity within 120 minutes. See Page 14 of listed report.

Profile properties

The following table is a summary of the currently available profiles, please see **Appendix A** for profile drawings.

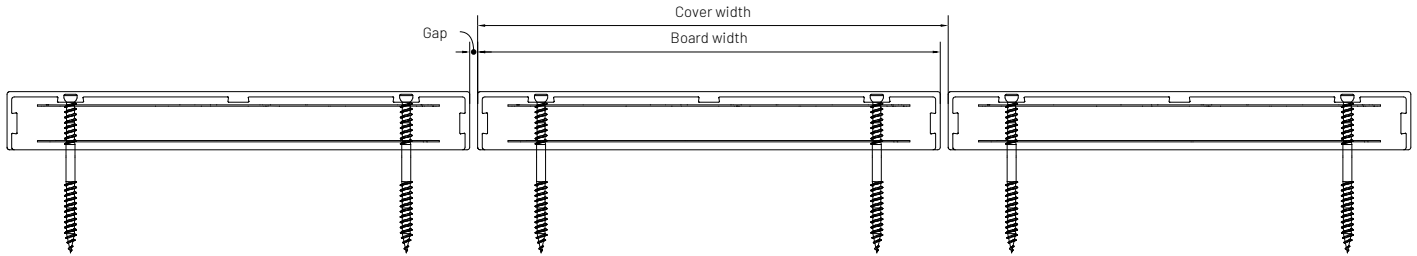

Profile ID	Application type	Board width mm (inch)	Thickness mm (inch)	Mass per meter ⁽⁴⁾ kg/m (lb/ft)	Cover width ⁽¹⁾ mm (inch)	Coverage ⁽²⁾ m/m ² (ft/ft ²)	Coverage mass ⁽³⁾ kg/m ² (lb/ft ²)
STZQJAZ03D25	Square edge profile	175 (6.89)	24 (0.95)	3.8 (2.5)	179 (7.0)	5.6 (1.69)	21.1 (4.3)
STZQJAZ03	Square edge profile	175 (6.89)	22 (0.87)	3.5 (2.3)	179 (7.0)	5.6 (1.72)	19.3 (3.9)
STJAZ07	Fascia board	185.5 (7.31)	16 (0.63)	3.5 (2.3)	180 (7.1)	5.3 (1.63)	14.2 (2.9)
STJAZ08	Bull nose edge profile	48 (1.89)	22 (0.87)	0.9 (0.6)	N/A	N/A	N/A
STZQJAZ11	Square edge bull nose profile	150 (5.91)	22 (0.87)	2.9 (2.0)	154 (6.1)	6.5 (2.00)	19.1 (3.9)
STZQJAZ09	Cladding profile	179 (7.05)	15.5 (0.62)	1.9 (1.3)	183 (7.2)	5.5 (1.68)	10.4 (2.13)

(1) Coverage width = Board width + an assumed typical gap of 6 mm.

(2) Coverage = 1000/Coverage width

(3) Coverage = Coverage x mass per meter.

(4) Mass = Density at 0.90 x Sectional area

Mechanical properties

Material specific mechanical properties

All information within this table is currently based on internal laboratory results of RegalBoard. See **Report No. 220929020SHF-001-R1** for full details.

Properties	Value	Test method	Notes
Tensile Strength	97.3 MPa (14 112.5 psi)	EN ISO 527-2:2012	See page 8 of listed report.
MOE	53.2 - 62.4 MPa (7 717.9 - 9 050.6 psi)	EN 15534-1:2014	
Charpy Impact Resistance	77.25 kJ/m ² (36.8 ft-lbf/in ²)	EN ISO 179-1:2010	Upon impact there was a partial break. Page 6 of listed report
Falling Mass Impact Resistance	No crack Max residual indentation 0.13 mm	EN 15534-1:2014	A Falling ball weighing 1000g was dropped from a height of 700 mm, the result was then recorded. See page 7 of listed report.

Profile flexural properties

Flexural properties of polymer composites can be influenced by the profile geometry and span. Typical properties of the RegalBoard material technology are captured below based on External test results of STBG2201011. See **Appendix A** for profile details.

Identifier	Span mm (in)	Modulus of rupture MOR MPa (PSI)	Modulus of Elasticity MOE MPa (KPSI)	Max Load Mean N (lbf)	Deflection at 500N mm (in)	Test Method	Notes
Dark brown	400 (16)	62.4 (9050.6)	2 447 (354.9)	9 460 (2127.6)	1.98 (0.078)	EN 15534-1:2014	See Report No. 220929020SHF-001-R1 . See Page9 of listed report.
Light brown		54.9 (7961.3)	2 356 (341.8)	7 883 (1772.6)	2.51 (0.099)		
Unspecified	300 (12)	53.2 (7717.9)	1 943 (281.9)	9 632 (2166.7)	1.83 (0.072)		

Please note that STBG201011 has since been superseded by STJAZ03. The primary update is the reduction dovetails, to more strategic fastening locations. There have been no changes below the neutral axis, and we have therefore assumed that these changes will have no significant affect.

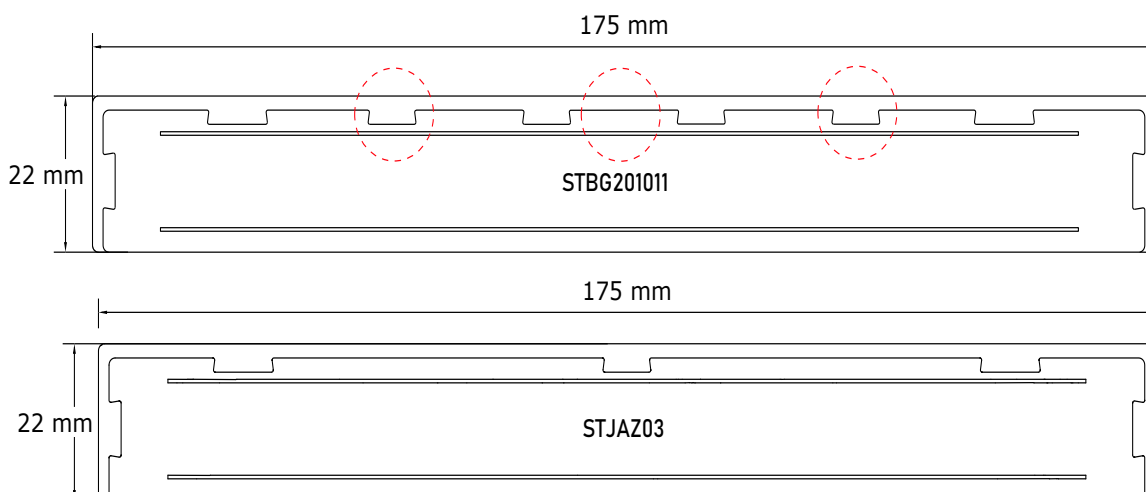

The following results were tested internally to determine the performance of the STJAZ03, at 450mm (17.7") spans.

Identifier	Span mm (in)	Modulus of rupture MOR MPa (PSI)	Modulus of Elasticity MOE MPa (KPSI)	Max Load Mean N (lbf)	Test Method	Notes
Dark brown	450 (17.7)	49.50 (7 179)	2 295 (332.9)	6 242 (1403)	Internal test method	See Internal Report No. 23.6.21-JAZ03

Moisture resistance under cyclic conditions.

The cyclic conditions involve immersing the test pieces in a water bath at $(20 \pm 1)^\circ\text{C}$ for 28 days in the first cycle, followed by 72 hours in the second and third cycles, with each cycle including a 24-hour freezing period and a 72-hour drying period, and finally conditioning the pieces for 72 hours after removal from the drying cabinet. Before testing the material.

Identifier	Span mm (in)	Bending strength					Test Method	Notes
		Original MPa (PSI)	Mean result After exposure MPa (PSI)	Mean Decrease in strength %	Minimum result After exposure MPa (PSI)	Maximum Decrease in strength %		
Dark brown	400 (16)	62.4 (9 050)	55.2 (8 006)	11.5	51 (7 397)	18.3	EN 15534-1:2014	See Report No. 220929020SHF-001-R1 See page 13 of listed report.3
Unspecified	300 (12)	53.2 (7 717)	46.1 (6 686)	13.3	40 (5 802)	24.8		

Nail and Screw Withdrawal and Pull Through Resistance

Fastener withdrawal tests were performed on a typical RegalBoard square edge decking installation, top fixing STBG2201011 to a frame with joists at spans of 406 mm using composite deck screws, 30 mm from any edge of the profile, with a 6mm gap between each board.

Properties	Value	Test Method	Notes
Nail and Screw Withdrawal	25.0 N/mm ² (3 625.9 PSI)	EN 15534-1:2014	See Report No. 220929020SHF-001-R1 M4.3 x 60mm (Minor diameter 3.0) See Pages 10 and 11 of the listed report.
Pull Through Resistance	84.1 N/mm ² (12 199 PSI)	EN 15534-1:2014	

Sectional properties

The following table provides a sectional property summary of the currently available RegalBoard profiles in typical board orientation. Please see Appendix A for profile drawings and further information.

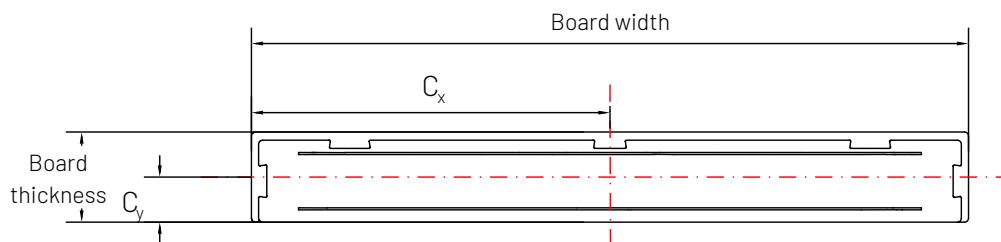

Profile details					Moments of inertia		Centroid		Elastic sectional modulus	
Profile ID	Application	Board width mm (inch)	Thickness mm (inch)	Area mm ² (in ²)	I _x mm ⁴ (in ⁴)	I _y mm ⁴ (in ⁴)	C _x mm ⁴ (in ⁴)	C _y mm ⁴ (in ⁴)	S _x mm ⁴ (in ⁴)	S _y mm ⁴ (in ⁴)
STZQJAZ03D25	Square edge profile	175 (6.89)	24 (0.95)	4 193 (6.5)	200 751 (0.49)	10 687 215 (25.68)	87.5 (3.45)	12.0 (0.48)	16 732 (1.03)	122 136 (7.46)
STZQJAZ03	Square edge profile	175 (6.89)	22 (0.87)	3 839 (5.96)	153 939 (0.37)	9 793 542 (23.53)	87.5 (3.45)	11.0 (0.44)	14 032 (0.86)	111 926 (6.83)
STJAZ07	Fascia board	185.5 (7.31)	16 (0.63)	2 992 (4.64)	63 491 (0.16)	8 760 871 (21.05)	93.8 (3.7)	8.0 (0.32)	7 955 (0.49)	93 449 (5.71)
STJAZ08	Bull nose edge profile	48 (1.89)	22 (0.87)	1 025 (1.59)	40 212 (0.1)	187 988 (0.46)	24.7 (0.98)	11.25 (0.45)	2 573 (0.16)	7 626 (0.47)
STZQJAZ11	Bull nose Square edge profile	150 (5.91)	22 (0.87)	3 265 (5.07)	130 279 (0.32)	6 011 617 (14.45)	75.7 (2.99)	11.0 (0.44)	11 779 (0.72)	7 9431 (4.85)
STZQJAZ09	Cladding Profile	179 (7.05)	15.5 (0.62)	2 118 (3.29)	36 417 (0.09)	5 317 524 (12.78)	92.1 (3.63)	8.9 (0.36)	4 090 (0.25)	57 728 (3.53)

Thermal properties

Typical properties of the RegalBoard material technology are captured below.

Properties	Results	Test method	Information
Coefficient of Thermal Expansion	38.7 x 10 ⁻⁶ mm/mm/°C (21.5 x 10 ⁻⁶ mm/mm/°F)	ISO 11359-2:2021	See Report No. 220929020SHF-001-R1. See Page 15 of the listed report.

Fire reaction properties

Decking Application – Test Summary

Fire reaction testing for Regalboard in decking applications is not currently available

Cladding Application – Test Summary

The Regalboard Cladding board (STZQJAZ09) was tested for fire reaction performance in accordance with EN 13501-1:2018, using both the EN 13823 (SBI) and EN ISO 11925-2 methods.

The samples were installed as a corner wall cladding application, fixed mechanically over a calcium silicate board (A2 substrate), with the aesthetic side exposed, using an ignition source placed at the bottom corner of the cladding system. The classification provided reflects the material's performance when used as wall cladding and was tested externally by SGS labs. Reference: SGS **Report No. AJFS2407007569RS**

Test Parameter	Result	Units	Requirement (D-class)	Notes
EN 13501 Classification	D-s3, d0			
FIGRA 0.4 MJ	380.9	W/s	≤ 750	
Lateral Flame Spread	No	-	No	Per EN13501 classifications -
THR600s	19.9 (18 844)	MJ (BTU)	-	D - Combustible materials - Medium contribution to fire
SMOGRA	324.9 (3496.6)	m ² /s ² (ft ² /s ²)	-	S3 - High smoke production
TSP600s	1083.7 (11663.6)	m ² (ft ²)	-	D0 - No flaming droplets
Flaming Droplets/Particles	No	-	None	
Vertical Flame Spread (30s)	≤150 (≤5.91)	Mm (in)	≤150 (≤5.91)	
Ignition of Filter Paper	No	-	No ignition	

Weathering

The environment to which materials are exposed influences how quickly the material will weather (or deteriorate). This includes degradation factors like UV exposure, oxidation or contact with organisms within the environment such as termites or mold. The impact of these factors is captured below. The impact of weathering on the flexural performance (material factor estimate) of the products is captured in the Mechanical properties section above.

Colour fade – UV resistance

One of the most visible effects of environmental exposure is colour change. The metric used to quantify this is ΔE , which measures the colour difference between an unexposed and a UV-aged sample.

- ΔE values range from 0 to 100, where values above 3 are generally perceptible to the human eye.
- Lower ΔE values indicate better colour stability.

To simulate long-term outdoor exposure, Regalboard™ samples were subjected to **accelerated UV ageing** using **ASTM G154**. This test includes cycles of UV light and moisture spray:

- **8 hours UV exposure at 60 °C (black panel temperature)**
- **0.25 hours water spray followed by 0.75 hours darkness at 50 °C**

Samples were assessed at regular intervals up to 4,000 hours. Results cover light, medium, and dark colour variants.

Name	Hours	ΔE	Observations	Test method	Notes
Unspecified	500	1.46	Perceptible through close observation	ISO 4892-2	Per internal reporting of external reports (External report not yet available)
	1000	1.61			
	1500	1.89			
	2000	TBD			

The following colours were tested before the secondary cap had additional UV stabilisers and colourants were added

Name	Hours	ΔL	Observations	Test method	Notes
Golden	1000	0.59	Not perceptible by human eyes	ASTM G154-2016	Per internal reports.
	2000	1.54	Perceptible through close observation		
	3000	2.38			
	4000	2.81			
Brass	1000	0.76	Not perceptible by human eyes	ASTM G154-2016	Per internal reports.
	2000	1.71	Perceptible through close observation		
	3000	2.53			
	4000	2.99			
Brown	1000	0.93	Not perceptible by human eyes	ASTM G154-2016	Per internal reports.
	2000	1.95	Perceptible through close observation		
	3000	2.67			
	4000	3.39			
Grey	1000	0.89	Not perceptible by human eyes	ASTM G154-2016	Per internal reports.
	2000	1.89	Perceptible through close observation		
	3000	2.53			
	4000	3.21			

Slip resistance

Slip resistance refers to a surfaces ability to prevent people from slipping or losing their footing. There are various methods used to measure slip resistance. These tests provide a measurement of slip resistance that can be used to compare different flooring materials. Slip resistance is influenced by factors such as the material and its surface, the angle of incline, the type of shoe being worn, and the presence of moisture or multiple contaminants.

The provided slip resistance ratings were obtained using the Pendulum test method to determine both R, ABC and HSE equivalent ratings. The HSE has established that there is an approximate cross reference between the DIN51130 (R-Rating) and DIN51097 (ABC rating) tests, and the Pendulum Test Values (PTV). This cross-reference allows for comparison and correlation between the different rating systems.

Property	Direction	Minimum PTV	Classification	Requirement	Test method	Notes
Wet Pendulum Test	Longitudinal	62	P5	P5 requires PTV > 44 More than 36 Low change of slip	EN 15534-1:2014	See Report No. 220929020SHF-001-R1 Page 5.
	Horizontal	65				
Dry condition test	Longitudinal	78				
	Horizontal	86				

Slip resistance Oil Ramp test

The oil ramp test assigns an R rating to flooring materials by evaluating their slip resistance under oily conditions to ensure safety and compliance with industry standards.

Property	Angle	Rating	Requirement	Test method	Notes
Oil-wet ramp test	21.6	R11	Greater than 27	DIN 51130:2024	See Report No. 220929020SHF-001-R1 Page 16

Slip resistance after wearing

The surface of the RegalBoard deck profile underwent accelerated wear tests, with slip resistance measured at key points to assess the impact of wear on the product's slip resistance.

Property	Mean PTV	Classification	Requirements	Test method	Notes
Accelerated Wear Test	65	P5	P5 are >44	AS 4586:2013	See ATTAR Report 19648.5 Page 2
After 100 cycles	52	P5	More than 36	AS 4586:2013	
After 500 cycles	41	P4	Low change of slip	AS 4586:2013	
After 1000 cycles	36	P3	More than 24 moderate change of slip	AS 4586:2013	
After 5000 cycles	26	P2	Less than 24 a high change of slip.	AS 4586:2013	

Disclaimer and copyright

Document disclaimer

The provided information is offered in good faith as accurate but without guarantee. Eva-Last® makes no warranties or representations of any kind (express or implied) about the accuracy, adequacy, currency, or completeness of the information, or that it is necessarily suitable for the intended use.

Compliance with this document does not guarantee immunity from breach of any statutory requirements, building codes or relevant standards. The final responsibility for the correct design and specification rests with the designer and, for its satisfactory execution, with the contractor. Appropriate warnings and safe handling procedures should be provided to handlers and users.

While most data have been compiled from research, case histories, experience and testing, small changes in the environment can produce marked differences in performance. The decision to use a material, and in what manner, is made at your own risk. The use of a material and method may therefore need to be modified to its intended end use and environment.

Eva-Last®, its directors, officers or employees shall not be responsible for any direct, indirect, or special loss or damage arising from, or because of, use of, or reliance upon, any information contained in this document, or other documents referenced herein. Eva-Last® expressly disclaims any liability which is based on or arises out of, the information or any errors, omissions, or misstatements herein.

Drawing disclaimer

All dimensions and specifications are offered in good faith as accurate but without guarantee. The information captured herein may not contain complete details. Eva-Last® makes no warranties or representations of any kind (express or implied) about the accuracy, adequacy, currency, or completeness of the information, or that it is necessarily suitable for the intended use.

Compliance with this document does not guarantee immunity from breach of any statutory requirements, building codes or relevant standards. The final responsibility for the correct design and specification rests with the designer and, for its satisfactory execution, with the contractor.

Utilisation disclaimer

Legislation may differ between jurisdictions. Before installing any Eva-Last product, ensure that the application is rational and complies with the local regulations and building codes. Wherever necessary, consult a suitably qualified professional. Be sure to comply with material manufacturer specifications. Where manufacturers and building codes differ, revert to the building code requirements. Check that your choice of product is suitable for its intended application. For further product specification and information visit www.eva-last.com.

Copyright

If reprinted or reproduced or utilised in any form Eva-Last should be acknowledged as the source of the information.

Eva-Last periodically updates the information contained in this document as well as that of the Eva Last documents that have been referenced herein. Before using this document, please refer to the Eva-Last website (www.eva-last.com) for the most up-to-date documents. Please also refer to the applicable websites.

Contact information

Eva-Last

Email: info@eva-last.com

Website: www.eva-last.com

Appendix A
Profiles Drawings

Profile properties

Product code	STZQJAZ03D25
Sectional area (mm ²)	4 194
Approximate mass (kg/m)	3.9

**Sectional properties**

I_x (mm ⁴)	200 751
I_y (mm ⁴)	10 687 215
C_x (mm)	87.5
C_y (mm)	12.0
S_x (mm ³)	16 732
S_y (mm ³)	122 136

Drawing title

STZQJAZ03D25 - 175 x 24 Square edge deck board

File name

2024-06-19 - - TDS - Version 1.0

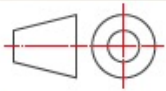
File details

Drawing number	01
Date	June 19, 2024
Page	1 of 7
Scale	NTS

Unless otherwise specified all dimensions are in millimeters.

Issued for information. See supporting documentation for disclaimers and details.

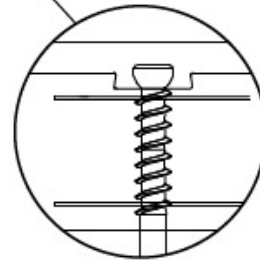
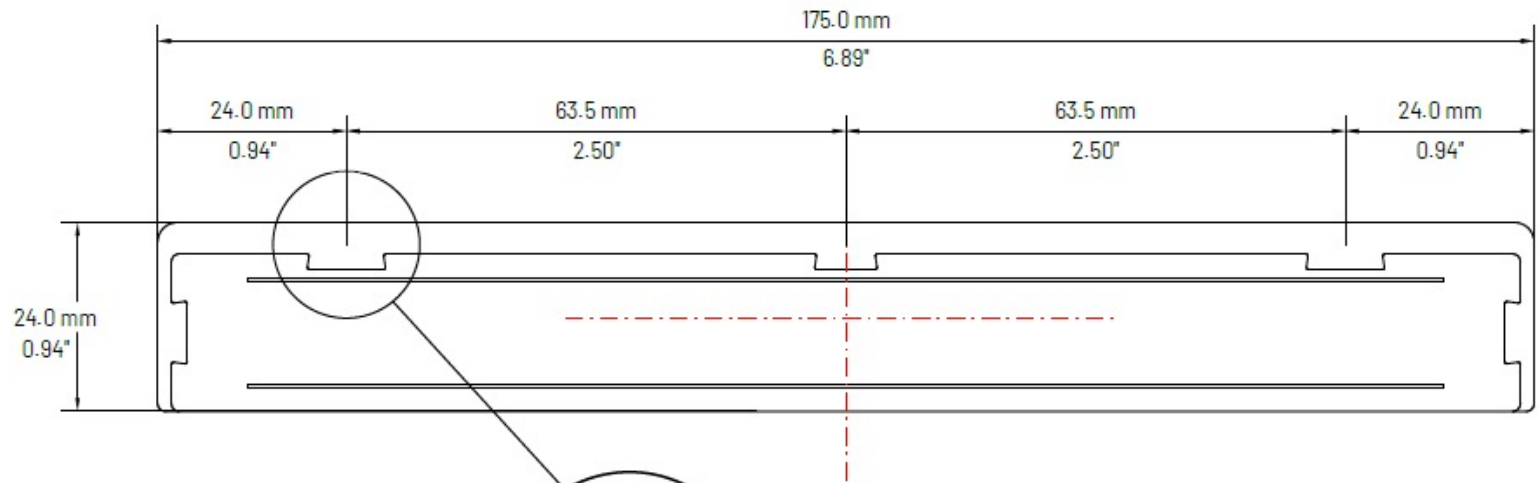

Recommended fastener position

REGALBOARD

Profile properties	
Product code	STZQJAZ03
Sectional area (mm ²)	3 839
Approximate mass (kg/m)	3.5



Sectional properties	
I_x (mm ⁴)	153 939
I_y (mm ⁴)	9 793 542
C_x (mm)	87.5
C_y (mm)	11.0
S_x (mm ³)	14 032
S_y (mm ³)	111 926

Drawing title
STZQJAZ03 - 175 x 22 Square edge profile

File name
2024-06-19 - - TDS - Version 1.0

File details



Drawing number	01
Date	June 19, 2024
Page	2 of 7
Scale	NTS

Unless otherwise specified all dimensions are in millimeters.

Issued for information. See supporting documentation for disclaimers and details.

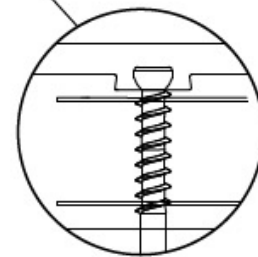
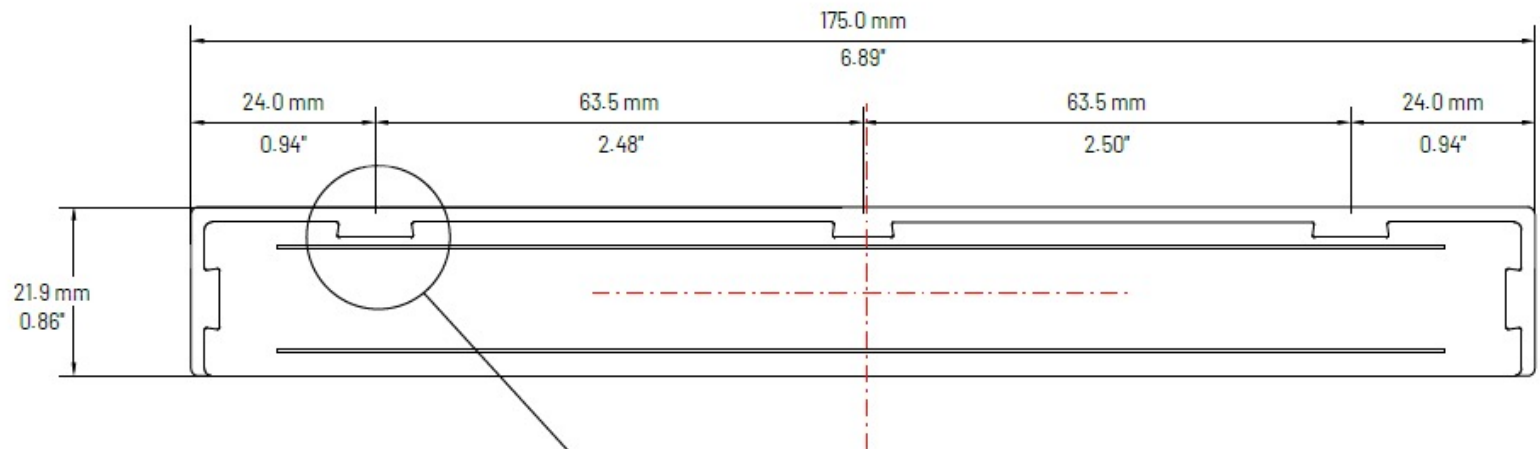

Recommended fastener position

REGALBOARD

Profile properties

Product code	STJAZ07
Sectional area (mm ²)	2 992
Approximate mass (kg/m)	2.8



Sectional properties

I _x (mm ⁴)	63 491
I _y (mm ⁴)	8 760 872
C _x (mm)	93.75
C _y (mm)	7.98
S _x (mm ³)	7 956
S _y (mm ³)	93 446

Drawing title

STJAZ07 - 185.5 x 16 - Fascia board

File name

2024-06-19 - - TDS - Version 1.0

File details



Drawing number	01
Date	June 19, 2024
Page	3 of 7
Scale	NTS

Unless otherwise specified all dimensions are in millimeters.

Issued for information. See supporting documentation for disclaimers and details.

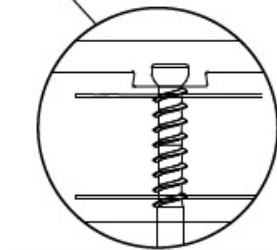
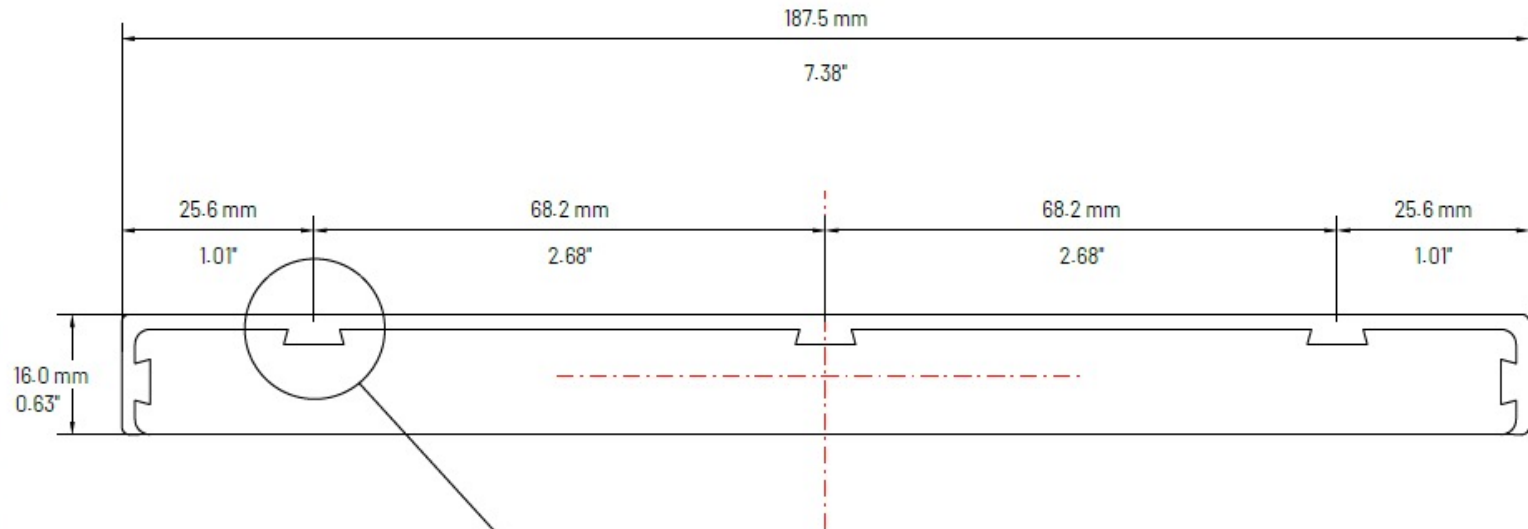

Recommended fastener position

REGALBOARD

Profile properties

Product code	STJZ08
Sectional area (mm ²)	1025
Approximate mass (kg/m)	1.2



Sectional properties

I_x (mm ⁴)	40 212
I_y (mm ⁴)	187 989
C_x (mm)	24.65
C_y (mm)	11.25
S_x (mm ³)	2 573.5
S_y (mm ³)	7 626

Drawing title

STJAZ08 - 48 x 22 - Bull nose edge board

File name

2024-06-19 - - TDS - Version 1.0

File details



Drawing number	01
Date	June 19, 2024
Page	4 of 7
Scale	NTS

Unless otherwise specified all dimensions are in millimeters.

Issued for information. See supporting documentation for disclaimers and details.

REGALBOARD

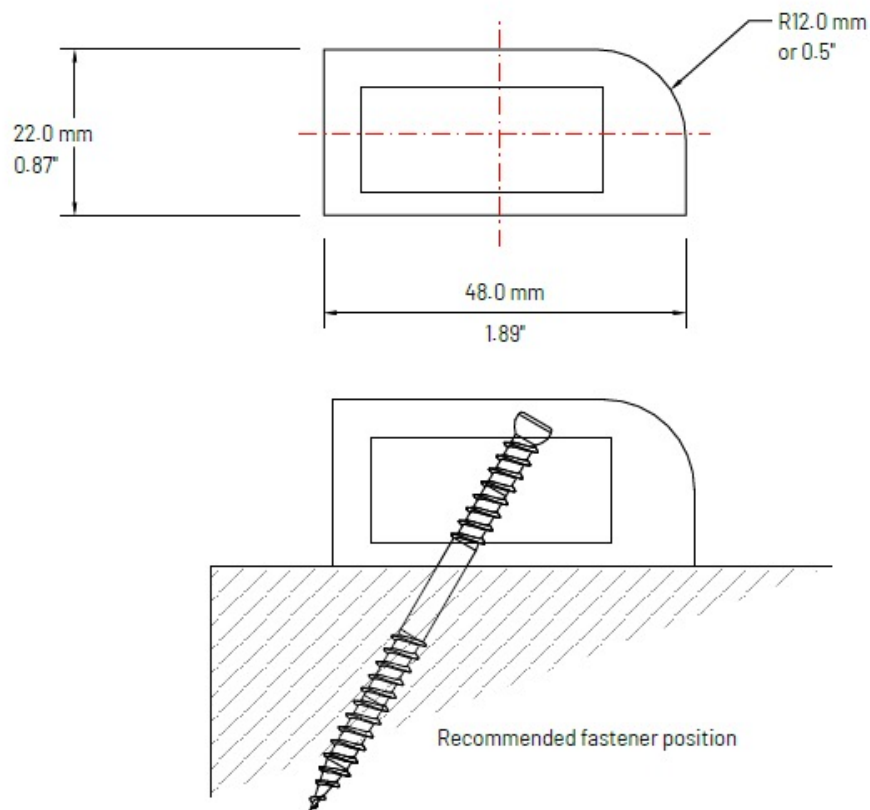

Profile properties	
Product code	STZQJAZ11
Sectional area (mm ²)	3 265
Approximate mass (kg/m)	3.00



Sectional properties	
I _x (mm ⁴)	130 279
I _y (mm ⁴)	6 011 618
C _x (mm)	75.68
C _y (mm)	11.06
S _x (mm ³)	11 779
S _y (mm ³)	79 432

Drawing title
STZQJAZ11 - 150 x 22 - Deck board

File name
2024-06-19 - - TDS - Version 1.0

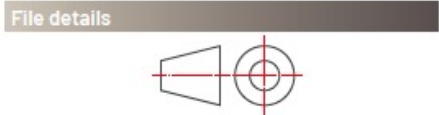

Drawing number	01
Date	June 19, 2024
Page	5 of 7
Scale	NTS

Unless otherwise specified all dimensions are in millimeters.

Issued for information. See supporting documentation for disclaimers and details.

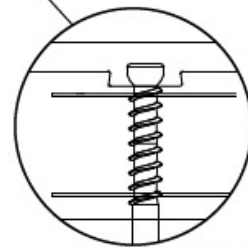
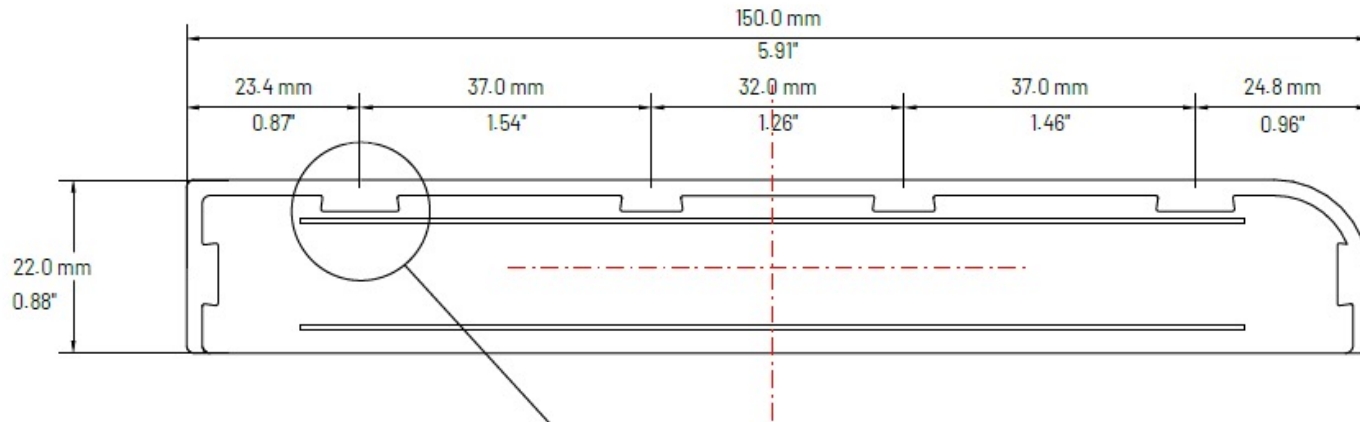

Recommended fastener position

REGALBOARD

Profile properties	
Product code	STZOJAZ09
Sectional area (mm ²)	2 118
Approximate mass (kg/m)	2.0



Sectional properties	
I _x (mm ⁴)	36 417
I _y (mm ⁴)	5 317 524
C _x (mm)	92.1
C _y (mm)	8.90
S _x (mm ³)	4 091
S _y (mm ³)	57 728.0

Drawing title
STZOJAZ09 - 179 x 15.5 - Cladding board

File name
2024-06-19- - TDS - Version 1.0

File details

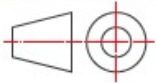

Drawing number	01
Date	June 19, 2024
Page	6 of 7
Scale	NTS

Unless otherwise specified all dimensions are in millimeters.

Issued for information. See supporting documentation for disclaimers and details.

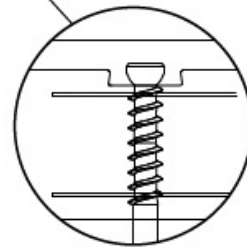
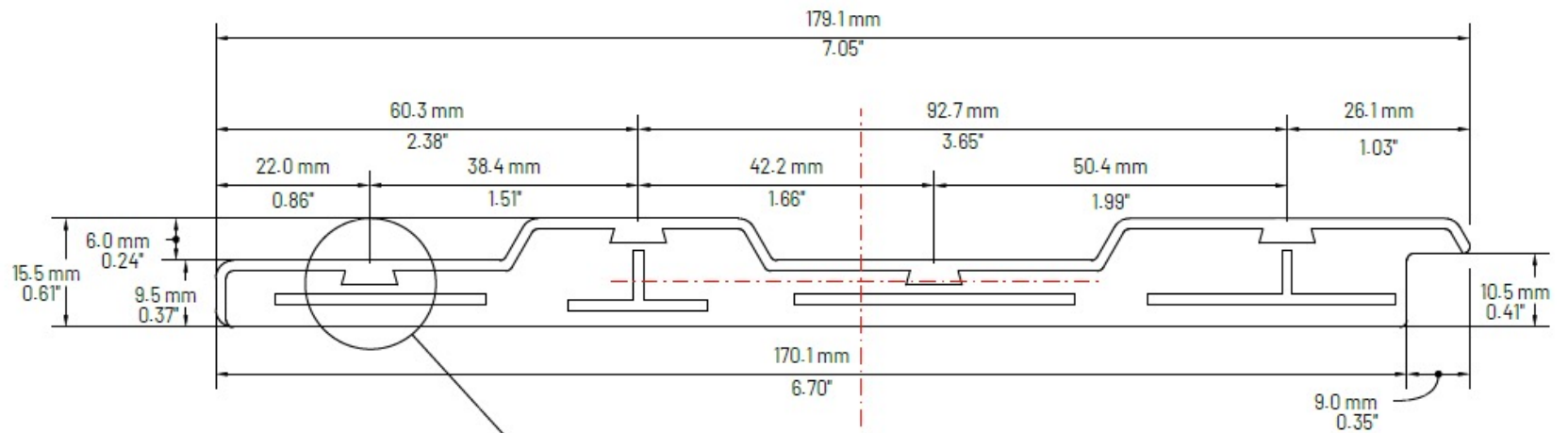

Recommended fastener position

REGALBOARD

Profile properties

Product code	M3040
Sectional area (mm ²)	
Approximate mass (kg/m)	



Sectional properties

I _x (mm ⁴)	
I _y (mm ⁴)	
C _x (mm)	
C _y (mm)	
S _x (mm ³)	
S _y (mm ³)	

Drawing title

M3040 - M3.0 x 40 Secret top fixing screw

File name

2024-06-19 - TDS - Version 1.0

File details



Drawing number	01
Date	June 19, 2024
Page	7 of 7
Scale	NTS

Unless otherwise specified all dimensions are in millimeters.

Issued for information. See supporting documentation for disclaimers and details.

REGALBOARD

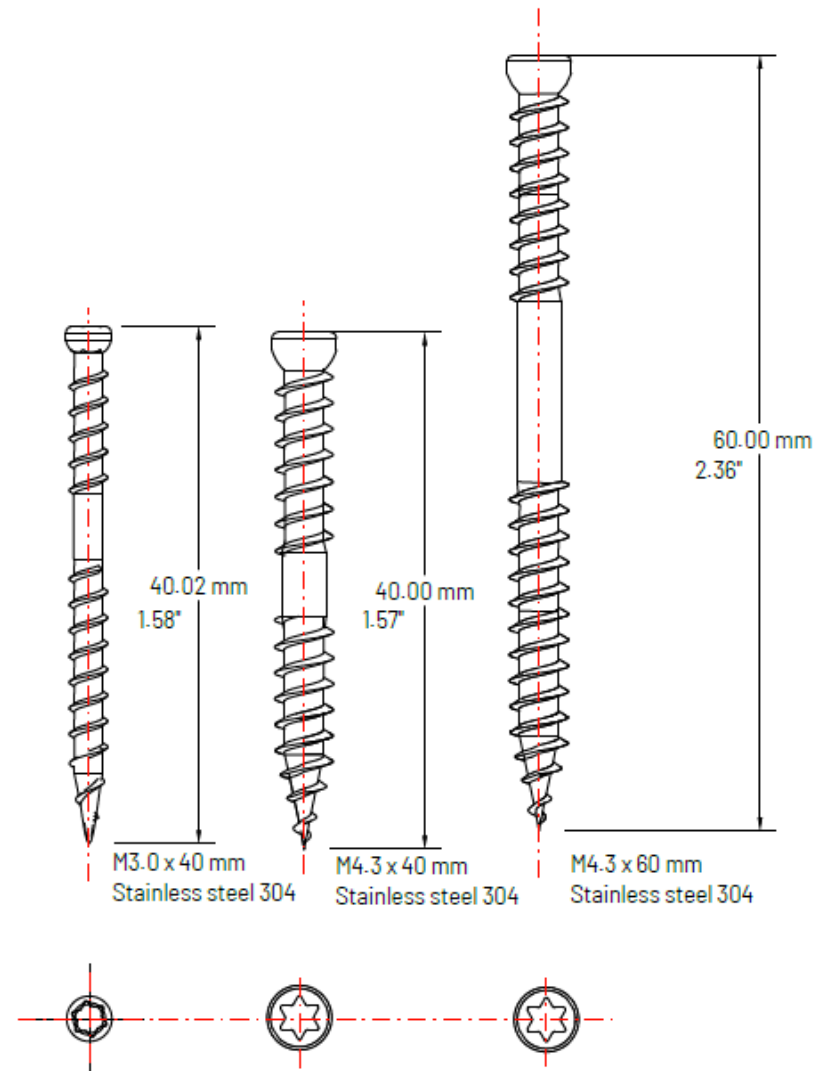

Appendix B
Chemical compatibility

When maintaining and cleaning your deck, it is important to be aware of materials that may cause damage. Strong detergents, high concentration alcohols (above 75%), strong acids or alkali detergents, oxidizers, and certain chemical solvents like esters, ketones, benzene, and undiluted chlorine can be particularly harmful. These substances are not compatible with the protective cap on RegalBoard decking boards. To ensure the longevity and appearance of your deck, it is crucial to prevent these materials from contacting the surface.

Below is an extensive (though not complete) list of common substances and solutions known to negatively influence the polyurethane surface of RegalBoard. It is important to check material compatibility when choosing chemicals that the product may encounter, as they may prematurely degrade the product. These may include ingredients in cleaning products, pool additives, and even oils and saps from local vegetation.

NB- Always perform a patch test using any chemicals on a small, inconspicuous area of the deck, or a deck sample before proceeding with full application.

Chemical Interaction Impact Checklist

Chemical Component	Common Name	Found in
Strong acids and bases		
Sulfuric Acid*	Battery acid	Battery acid, fertilizer production, drain cleaners
Ammonia, Anhydrous	Ammonia	Cleaning agents, fertilizers, refrigeration systems
Ammonium Hydroxide	Ammonia solution	Cleaning agents, water treatment, food processing
Calcium Hypochlorite	Bleaching powder	Bleach, water treatment, disinfectants
Hydrochloric Acid 37%	Muriatic acid	Cleaning agents, metal refining, food processing
Nitric Acid 10%	Aqua Fortis	Fertilizers, explosives, metal treatment
Solvents and alcohols		
Alcohol >75%*	Ethanol	Disinfectants, Hand sanitizers, cleaning agents
2-Butanone*	Methyl Ethyl Ketone (MEK)	Industrial solvent, Solvent, paint removers, coatings, adhesives
Acetone*	Acetone	Nail polish remover, solvents, cleaning agents, paint thinners
Aromatic Solvents*	Aromatic hydrocarbons	Paint, varnishes, adhesives, chemical intermediates
Benzene*	Benzene	Fuel, industrial chemicals, plastics, resins
Butyl Acetate*	Butyl Acetate	Lacquers, paints, coatings, adhesives
Butyl Aldehyde*	Butyraldehyde	Flavouring agent, fragrances, solvents, plastics
Ethyl Alcohol*	Ethyl Alcohol	Hand sanitizer, disinfectants, alcoholic beverages, fuel
Toluene*	Toluene	Paint thinner, adhesives, chemical intermediates, fuels
Xylene*	Xylene	Paint thinner, cleaning agents, solvents, rubber
Ethyl Acetate	Ethyl Acetate	Paint thinner, coatings, adhesives, cosmetics
Methyl Alcohol	Methanol	Antifreeze, solvents, fuel, formaldehyde production
Tetrahydrofuran	THF	Solvent, adhesives, coatings, pharmaceuticals
Trichloroethylene	Trichloroethylene	Dry cleaning solvent, degreasing agent, refrigerant
Turpentine	Turpentine	Paint thinner, solvent, medicinal uses, adhesives
Fuels and oils		
Kerosene*	Kerosene/Paraffin	Fuel, jet engines, heating, lamps
ASTM Fuel C	Test fuel	Fuel, testing purposes, calibration standards
ASTM Oil #4	Heavy fuel oil	Fuel, lubrication, hydraulic fluids

Chlorinated compounds		
Calcium Chloride	De-icer/Ice melt	De-icing agent, concrete acceleration, dust control, brine solution, Desiccants
Chlorinated Solvents*	Chlorinated Solvents	Cleaning agents, degreasing, paint removers
Carbon Tetrachloride	Carbon TET	Fire extinguishers, refrigerants, solvents, pesticide production
Chlorine Gas	Chlorine Gas	Disinfectants, water treatment, bleach production
Freon 22	R-22, HCFC-22	Refrigerants, air conditioning systems, blowing agents
Perchloroethylene	PERC, Tetrachlorethylene	Dry cleaning solvent, degreasing, chemical intermediates
Other		
Formaldehyde	"Formaldehyde (gas)	
Formic Acid	Methanolic acid	Preservatives, leather production, cleaning agents
Phenol	Carbolic acid	Disinfectants, resins, pharmaceuticals, plastics
Stoddard's Solvent 140°F	Mineral spirits	Cleaning agents, paint thinners, degreasing agents

*These materials have been proven to affect the product cap. Other materials are provided from a consolidation of various chemical compatibility charts.